



iLOQ S10 ONLINE SYSTEM – PLANNING GUIDELINES

This document provides instructions, installation examples and connection diagrams for the iLOQ S10 Online system. The system consists of the iLOQ N100 Net Bridge and connected iLOQ bus devices. These instructions are for a single Net Bridge installation. The system can have several Net Bridges and the principles apply for every Net Bridge in the system.

BASIC PLANNING GUIDELINES

- **iLOQ N100 Net Bridge works as a bus controller.** It has one main bus. The bus can be divided into 6 branches. The branching must be done all the way up from the Net Bridge.
- **The maximum number of connected iLOQ bus devices** depends on the chosen power supply, branch cable length and overall power consumption generated by iLOQ bus devices and cable losses.
- **Calculate overall bus power consumption** by adding up the overall power consumptions from each branch:
 1. Check the (door) installation power consumption from *Page 4* in order to get iLOQ bus device power consumption of a single installation.
 2. Add up all power consumptions of the installations in a single branch in order to get cumulative iLOQ bus device power consumption.
 3. Check the overall branch specific power consumption including cable losses from *Graph 1 on Page 2*.
 4. Add up all the branch specific power consumptions and ensure that the overall power consumption does not exceed the available bus power, which depends on the chosen power supply (see *Table 3*).
- **It is possible to use double wiring for powering the bus** to decrease cable losses, thus increasing the number of connected iLOQ bus devices (see *Graph 2 on Page 3*).
- **Place the Net Bridge as close to iLOQ bus devices as possible** to minimize cable power losses. However, place the Net Bridge in a secure location such as a technical room.
- **Use the bus power for powering only iLOQ bus devices. DO NOT use bus power for powering any other devices, such as electric locks.** However, the same DC power supply can be used for powering other external devices, such as electric locks, in addition to the Net Bridge. If this is the case, consider the number of wire pairs needed for other devices and branch the power all the way up from the DC power supply connectors, NOT from the Net Bridge connectors. Also ensure that the rated capacity of the power supply is sufficient to handle the additional load from external devices.
- **If necessary, please contact your iLOQ representative** for case-specific calculations and other cabling options.

iLOQ S10 ONLINE BUS SPECIFICATIONS

Table 1. Bus Layout (for a single iLOQ N100 Net Bridge)

Max. No. of Branches	Max. No. of Bus Devices	Max. Single Branch Length
6	32	300 m

Table 3. Max. Available Bus Power (depending on power supply)

PoE	PoE+	DC
10 W	20 W	30 W

Table 2. Cabling requirements

Cable Type	Min. for Single Wiring	Min. for Double Wiring
Cat 5 / Cat 6	2 x 2 wires	3 x 2 wires

Table 4. iLOQ Bus Device Power Consumption

iLOQ N102 Door Module	iLOQ N103 Key Reader / Hot Spot	iLOQ N104 RFID Reader
1 W	0.1 W	1 W

Internet



Local Area Network

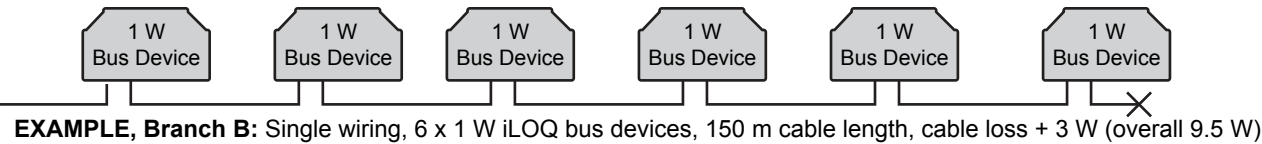
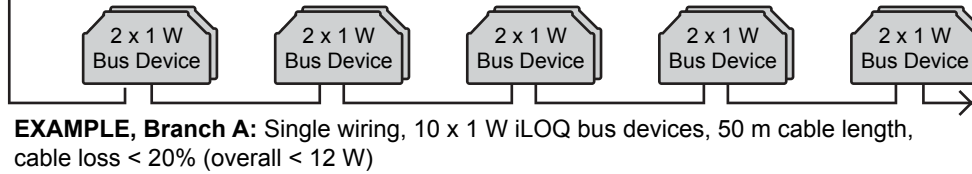
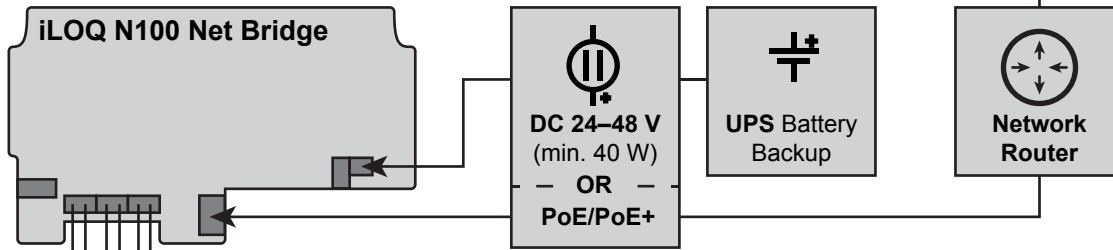

See Graph 1 for the ratio between maximum power and maximum branch cable length. The maximum values in this graph are calculated using a worst case scenario, where all the iLOQ bus devices operate at maximum power at the same time and all the devices are placed at the end of the branch cable.

Cat 5 / Cat 6 (min. 2 x 2 wires for iLOQ bus devices)

Graph 1. Maximum cumulative iLOQ bus device power and overall branch power consumption in relation to cable length

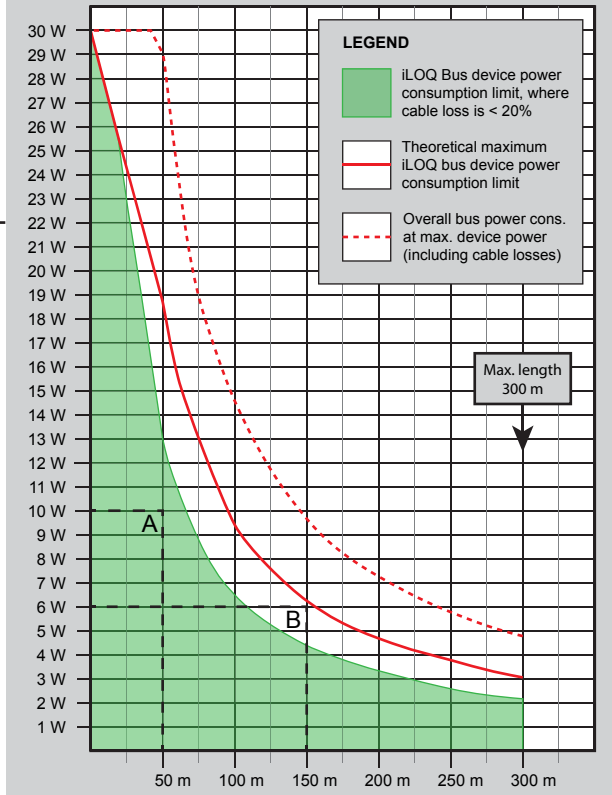

Title			
iLOQ S10 Online Bus Cabling Guidelines, Single Wiring			
Author	Date	ID and Rev.	Document type
	15.6.2015	53741/A	Cabling Diagram
Note		All rights reserved. Copyright © 2015 iLOQ Oy http://www.iloq.com	
2 / 13			

Internet



Local Area Network

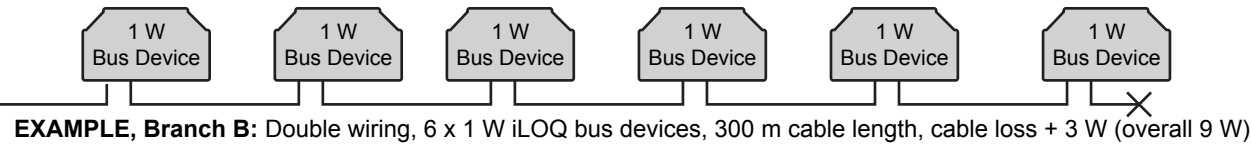
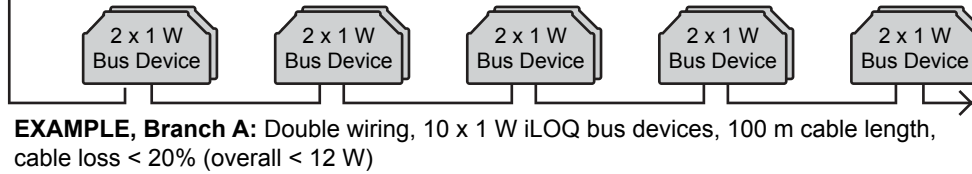
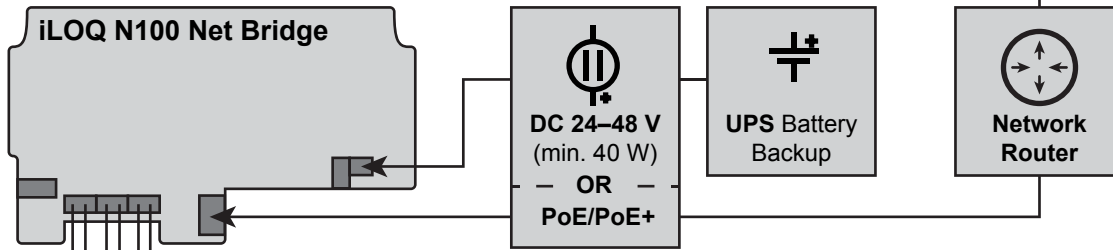

See *Graph 2* for the ratio between maximum power and maximum branch cable length. The maximum values in this graph are calculated using a worst case scenario, where all the iLOQ bus devices operate at maximum power at the same time and all the devices are placed at the end of the branch cable.

Cat 5 / Cat 6 (min. 3 x 2 wires for iLOQ bus devices)

Graph 2. Maximum cumulative iLOQ bus device power and overall branch power consumption in relation to cable length

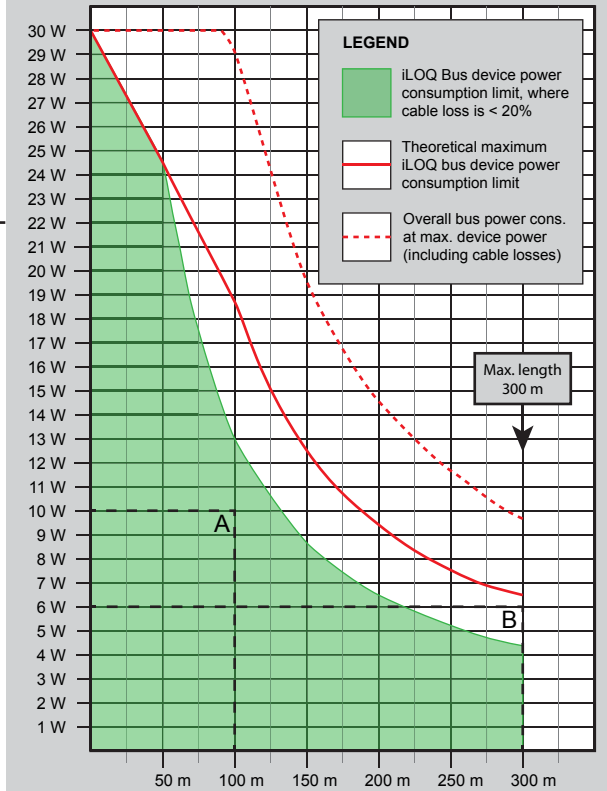

Title			
iLOQ S10 Online Bus Cabling Guidelines, Double Wiring			
Author	Date	ID and Rev.	Document type
	15.6.2015	53741/A	Cabling Diagram
Note		All rights reserved. Copyright © 2015 iLOQ Oy http://www.ilooq.com	
3 / 13			

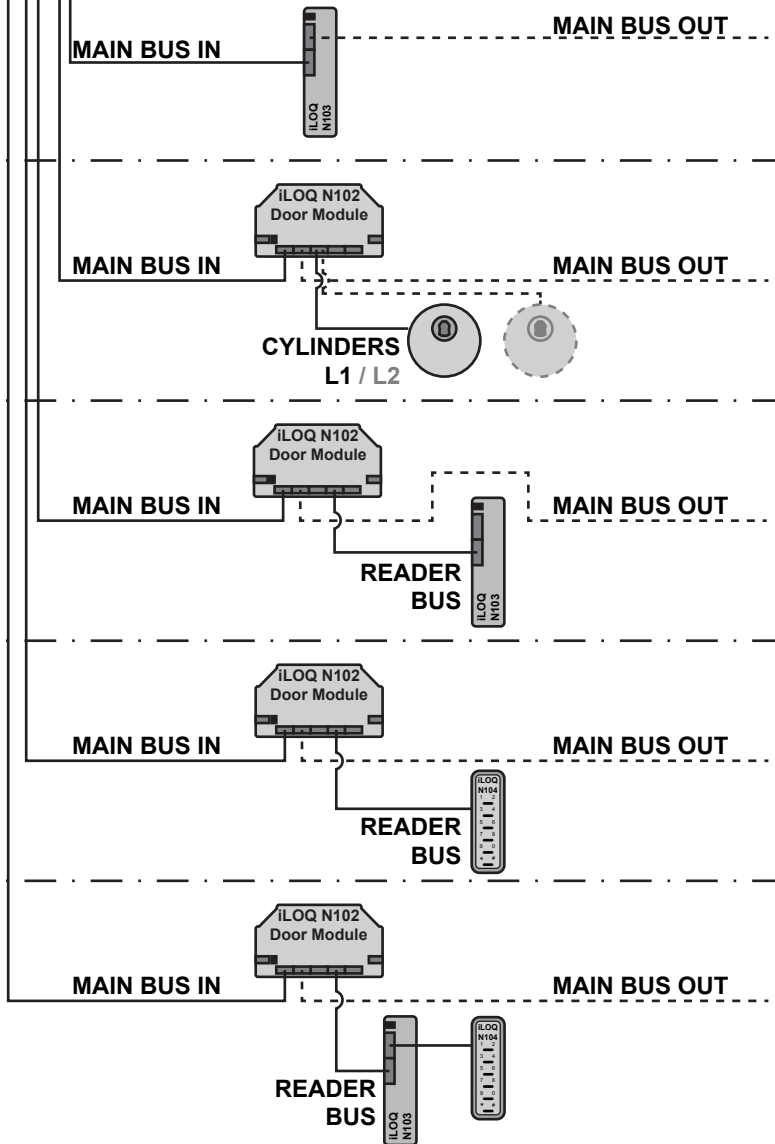
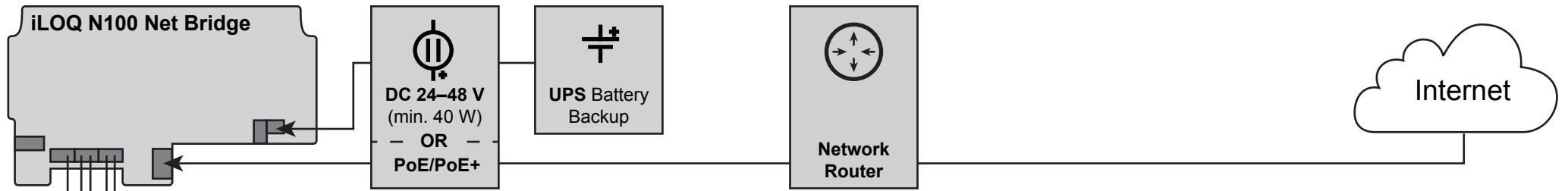

0,1 W Installation example 1:
iLOQ N103 as Hot Spot

1,0 W Installation example 2:
iLOQ N102 Door Module and Online Cylinders

1,1 W Installation example 3:
iLOQ N102 Door Module and iLOQ N103 as Key Reader

2,0 W Installation example 4:
iLOQ N102 Door Module and iLOQ N104 RFID Reader

2,1 W Installation example 5:
iLOQ N102 Door Module and iLOQ N103 as Key Reader and iLOQ N104 RFID Reader

Title iLOQ S10 Online Power Consumption Examples			
Author	Date 15.6.2015	ID and Rev. 53741/A	Document type Cabling Diagram
Note 4 / 13		All rights reserved. Copyright © 2015 iLOQ Oy http://www.iloq.com	

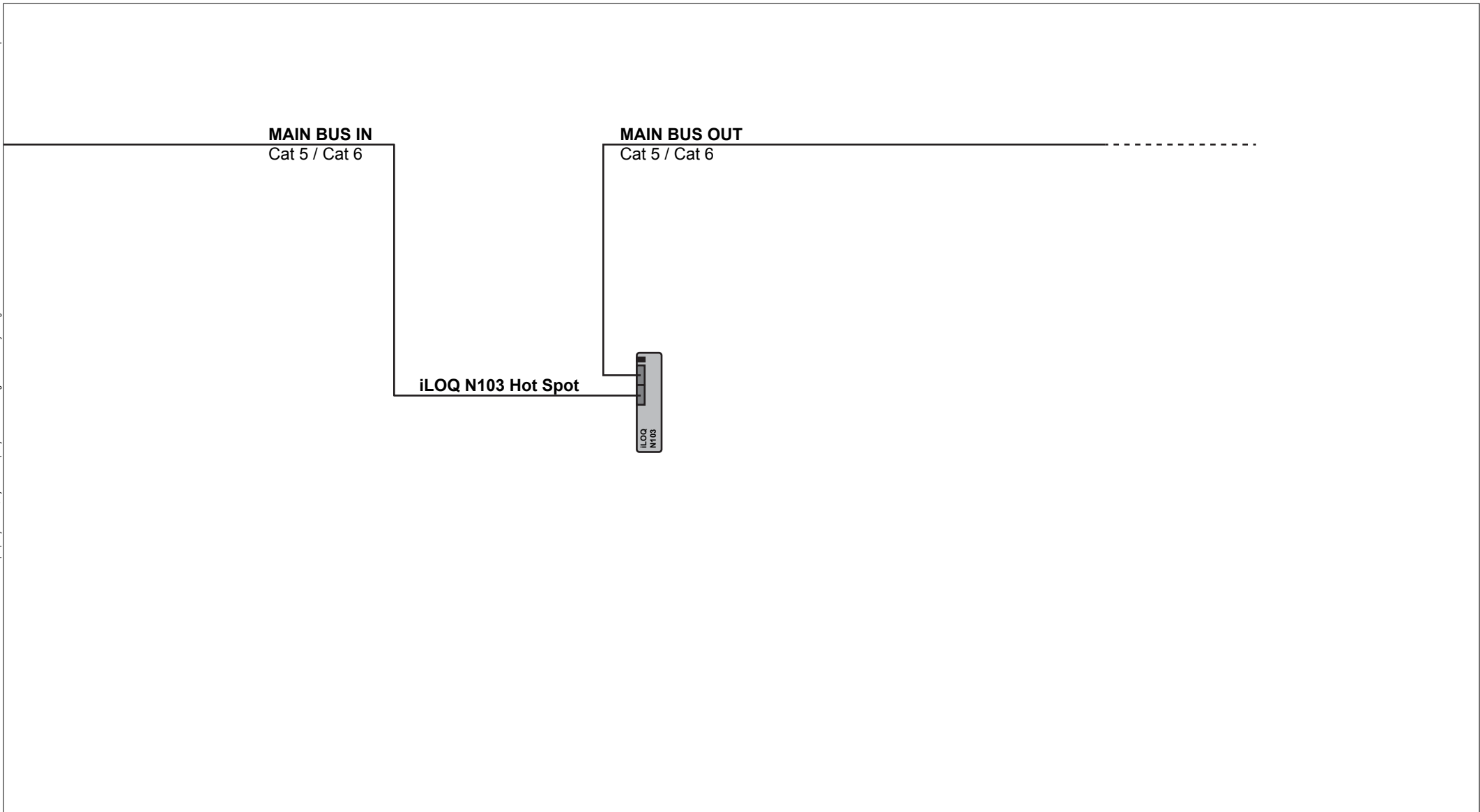

NOTES

- iLOQ N103 used as a Hot Spot

Title			
iLOQ S10 Online Installation Example 1			
Author	Date	ID and Rev.	Document type
	15.6.2015	53741/A	Cabling Diagram
Note			All rights reserved. Copyright © 2015 ILOQ Oy http://www.iloq.com
5 / 13			

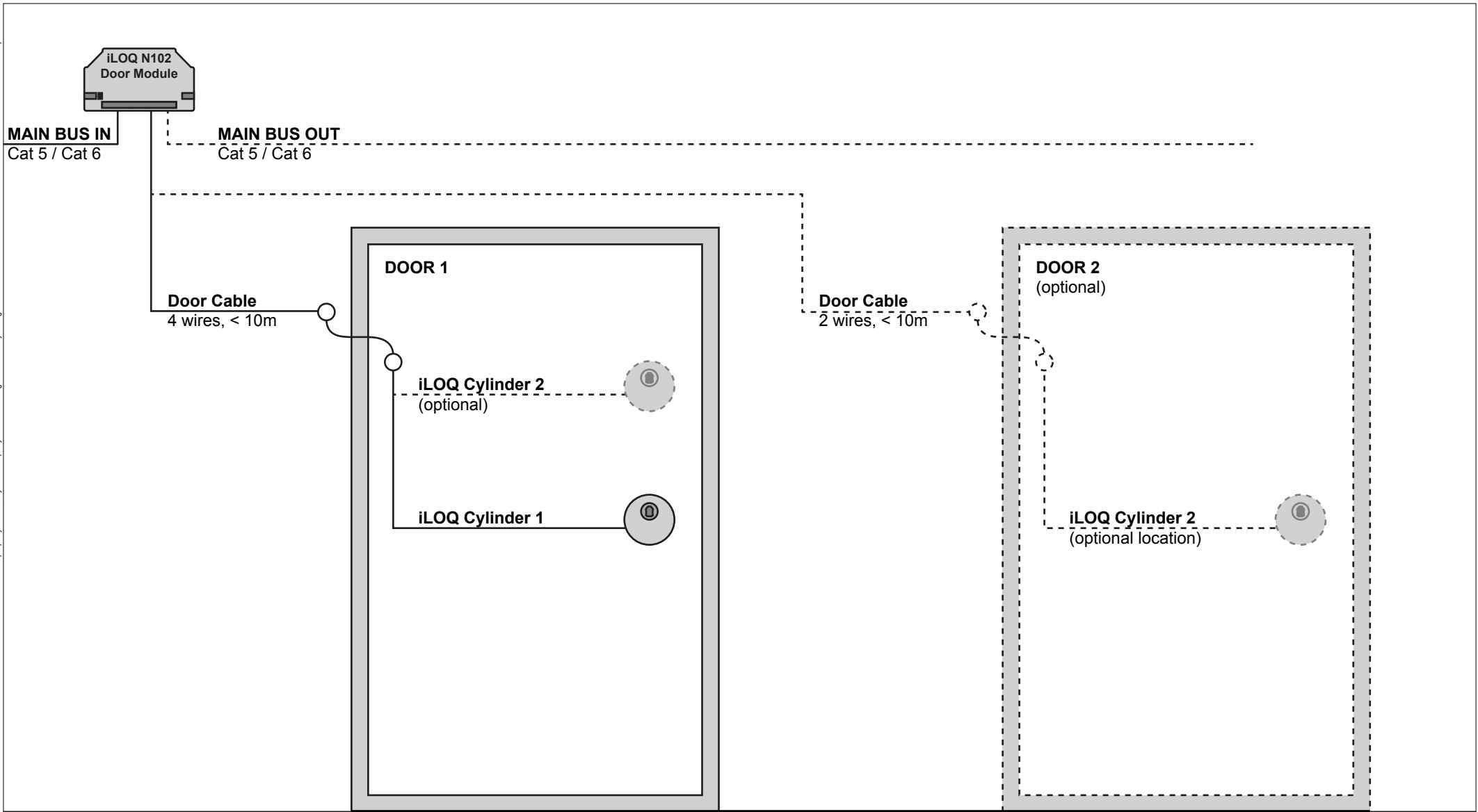

NOTES

- iLOQ S10 Online lock cylinders
- If the lock cylinders are installed on nearby separate doors, both doors must have the same ground potential

Title			
iLOQ S10 Online Installation Example 2			
Author	Date	ID and Rev.	Document type
	15.6.2015	53741/A	Cabling Diagram
Note			All rights reserved. Copyright © 2015 ILOQ Oy http://www.ilq.com
6 / 13			

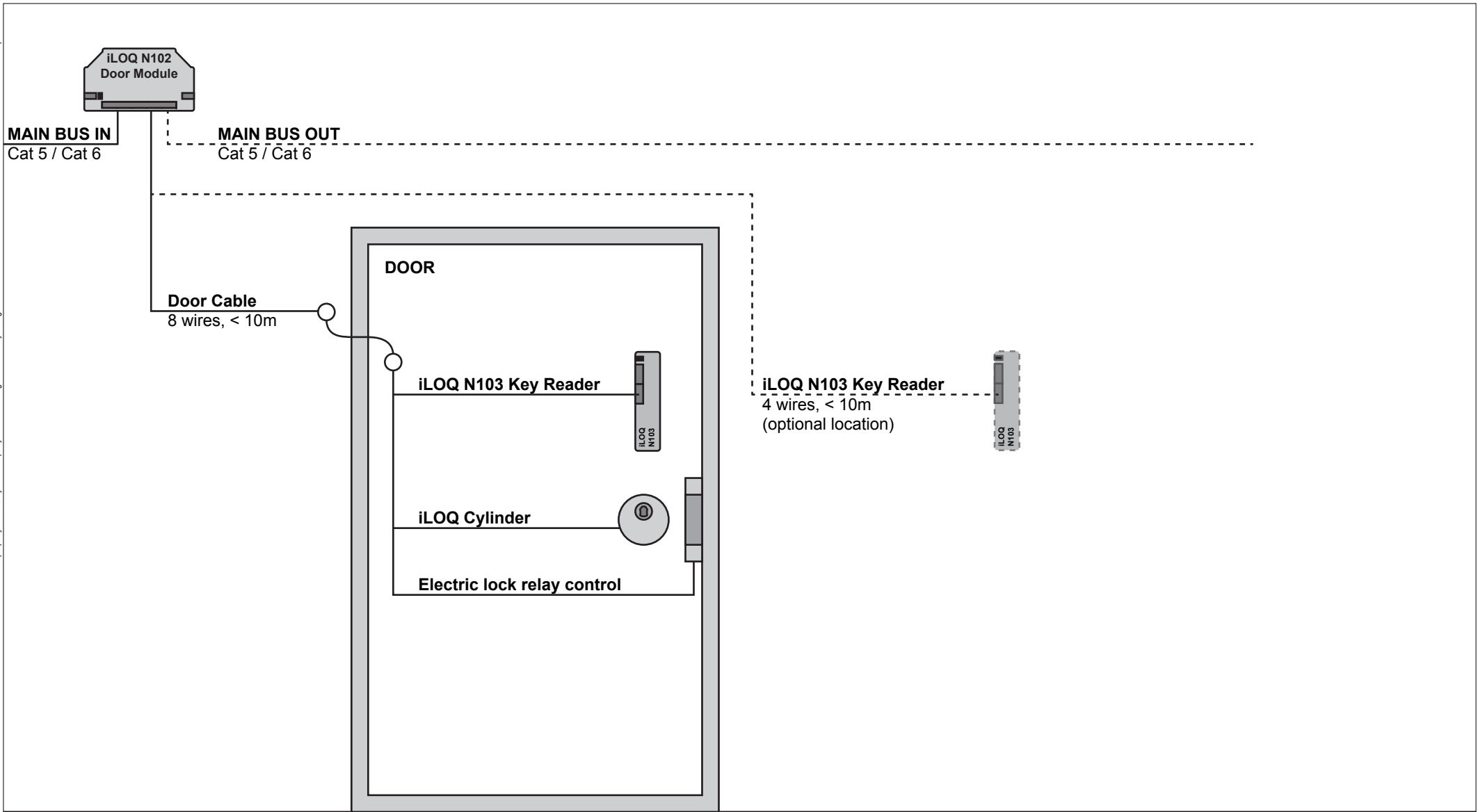

NOTES

- iLOQ S10 Online lock cylinder
- iLOQ N103 used as a combined key reader and a hot spot for controlling the electric lock
- Consider the number of wires needed for other door equipment (e.g. door opener push button and electric lock powering) and add them to the door cable wiring
- The powering of the electric lock must be arranged separately. Do not use iLOQ bus power for powering the electric lock.

Title			
iLOQ S10 Online Installation Example 3			
Author	Date	ID and Rev.	Document type
	15.6.2015	53741/A	Cabling Diagram
Note			All rights reserved. Copyright © 2015 iLOQ Oy http://www.iloq.com
7 / 13			
			

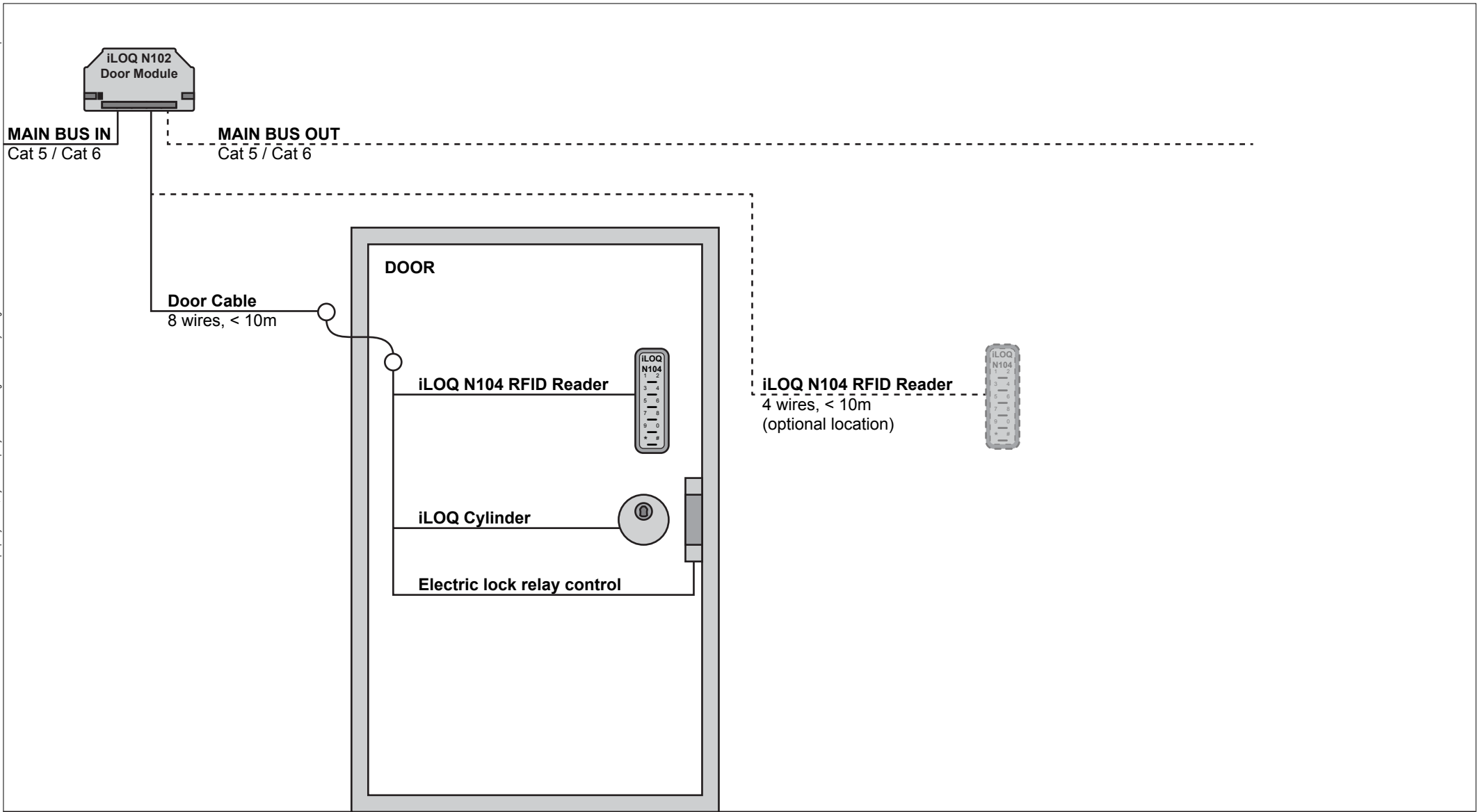

NOTES

- iLOQ S10 Online lock cylinder
- iLOQ N104 RFID Reader used for controlling the electric lock
- Consider the number of wires needed for other door equipment (e.g. door opener push button and electric lock powering) and add them to the door cable wiring
- The powering of the electric lock must be arranged separately. Do not use iLOQ bus power for powering the electric lock.

Title			
iLOQ S10 Online Installation Example 4			
Author	Date	ID and Rev.	Document type
	15.6.2015	53741/A	Cabling Diagram
Note			All rights reserved. Copyright © 2015 iLOQ Oy http://www.iloq.com
8 / 13			
			

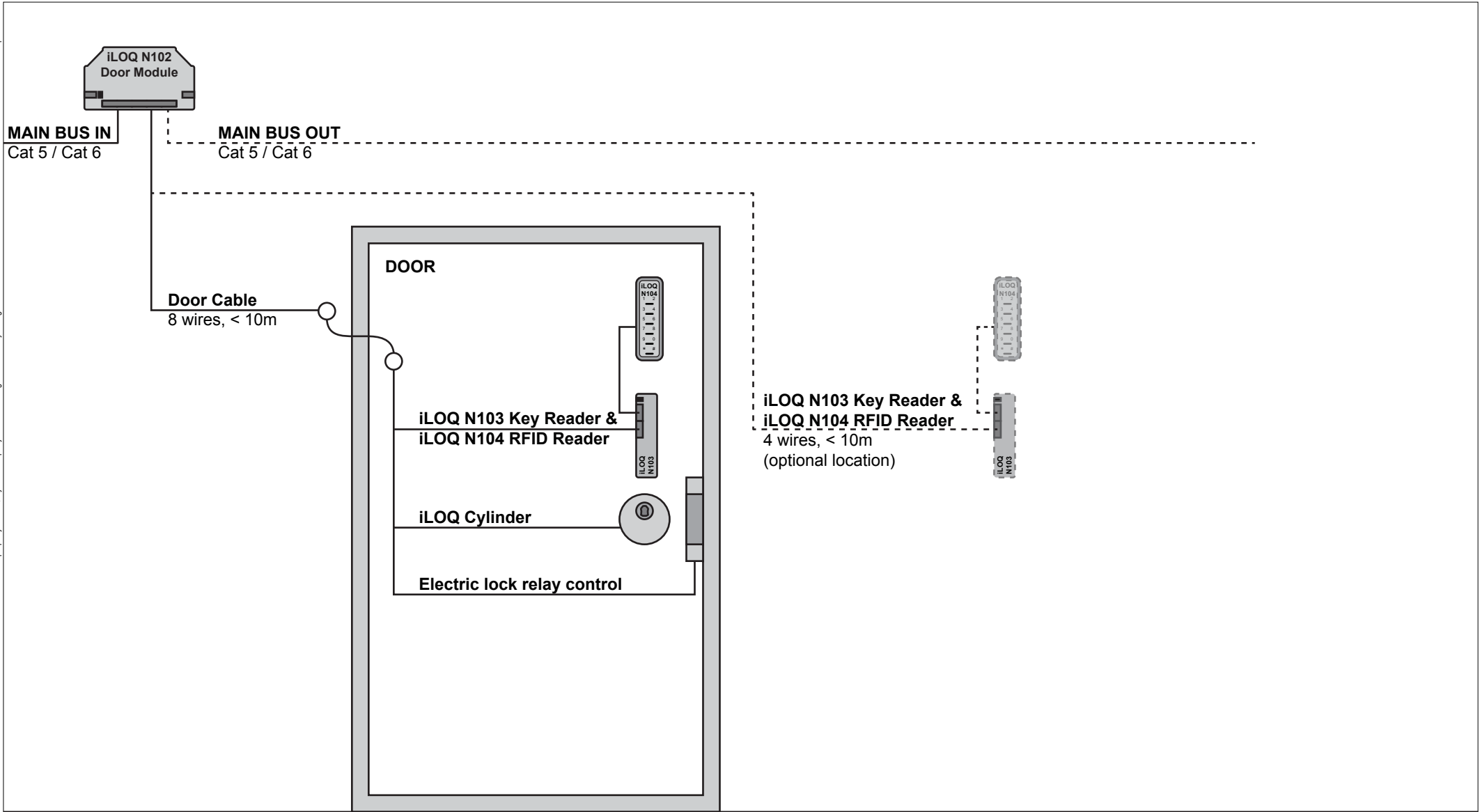

NOTES

- iLOQ S10 Online lock cylinder
- iLOQ N103 used as a key reader for controlling the electric lock
- Consider the number of wires needed for other door equipment (e.g. door opener push button and electric lock powering) and add them to the door cable wiring
- The powering of the electric lock must be arranged separately. Do not use iLOQ bus power for powering the electric lock.

Title			
iLOQ S10 Online Installation Example 5			
Author	Date	ID and Rev.	Document type
	15.6.2015	53741/A	Cabling Diagram
Note			
9 / 13			All rights reserved. Copyright © 2015 iLOQ Oy http://www.iloq.com
			

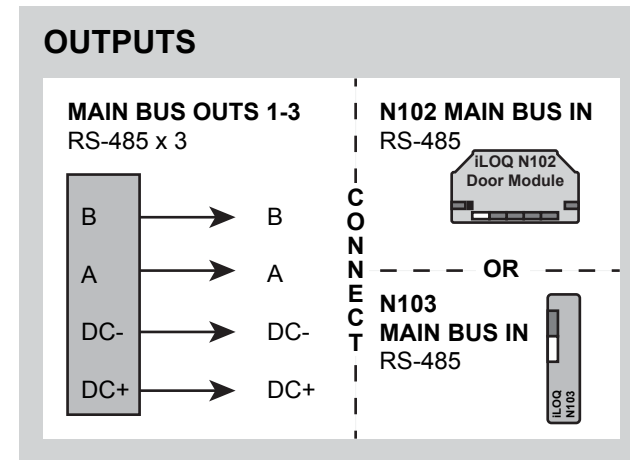
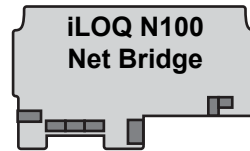
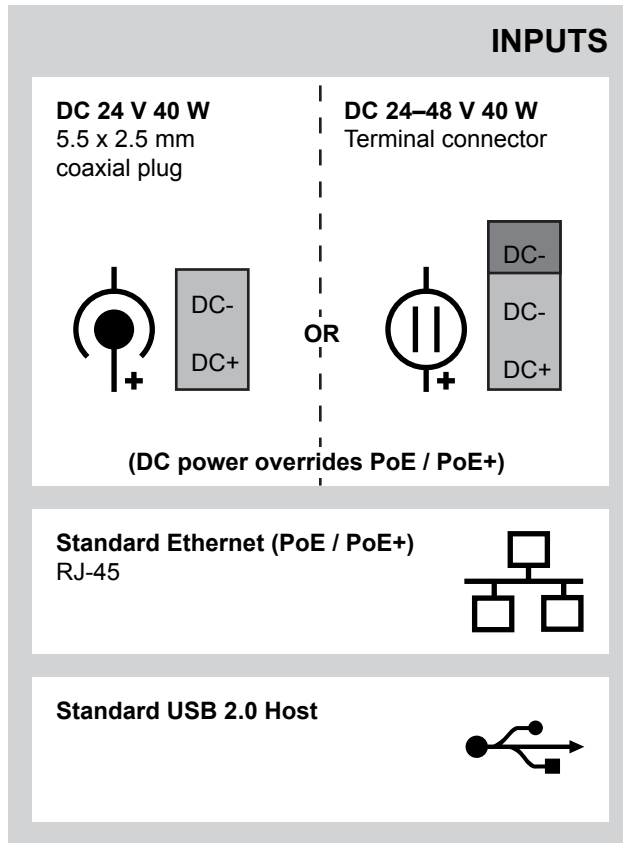

NOTES

- **It is strongly prohibited** to use the main bus power (**DC-**, **DC+**) for any other purpose than what is described in this document (e.g. powering an electric lock is forbidden).

Title iLOQ S10 Online N100 Net Bridge			
Author	Date 15.6.2015	ID and Rev. 53741/A	Document type Connection Diagram
Note		10 / 13	All rights reserved. Copyright © 2015 iLOQ Oy http://www.iloq.com 

INPUTS

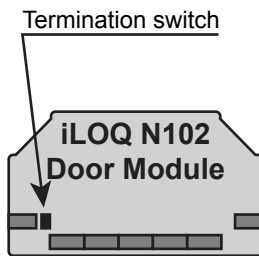
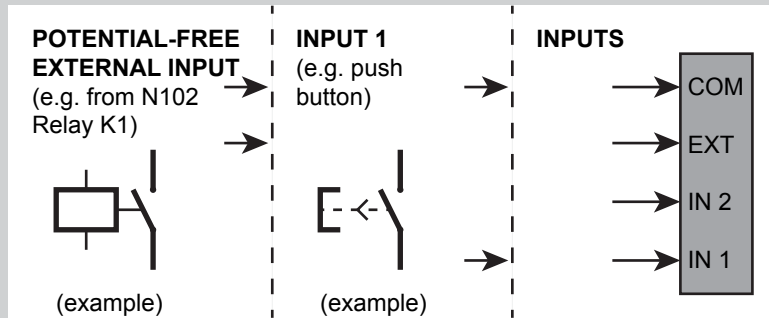
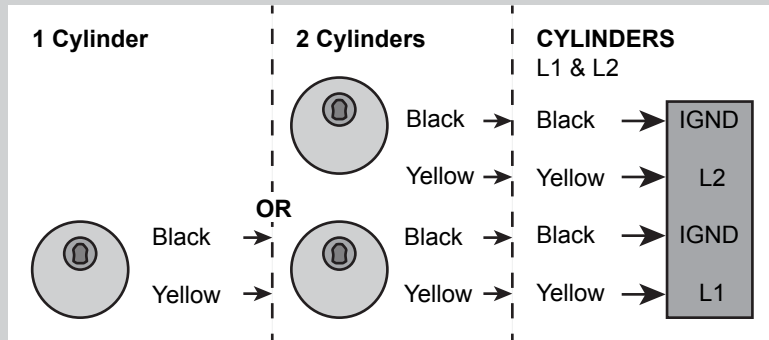
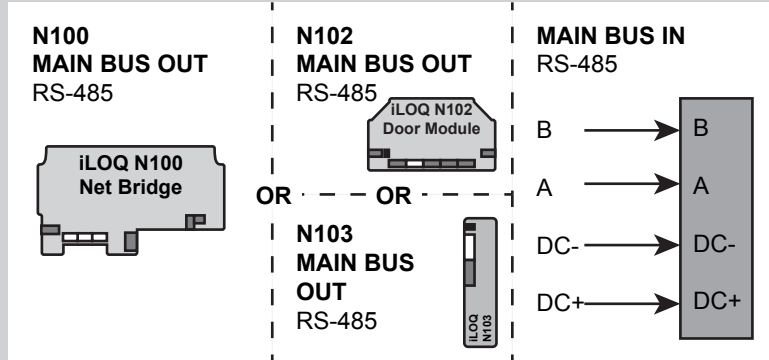

OUTPUTS

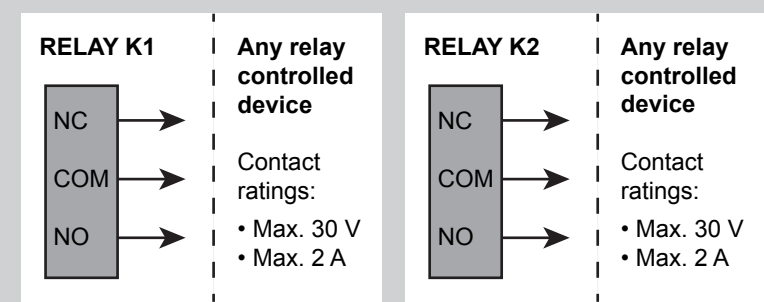
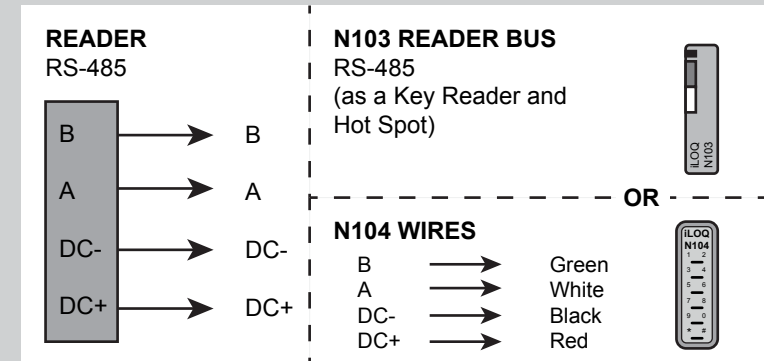
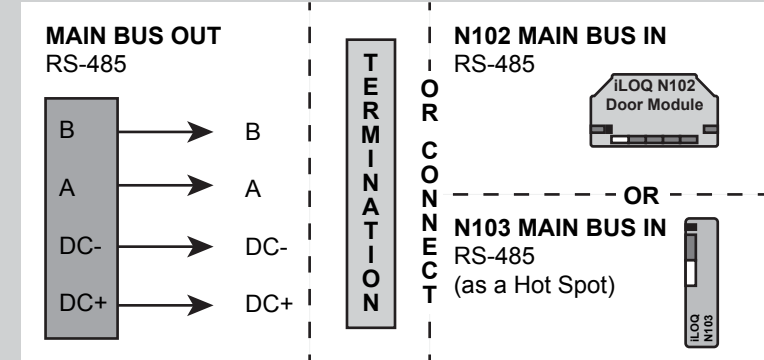

NOTES

- It is strongly prohibited to use the main bus power (DC-, DC+) for any other purpose than what is described in this document (e.g. powering an electric lock is forbidden).

Title			
iLOQ S10 Online N102 Door Module			
Author	Date	ID and Rev.	Document type
	15.6.2015	53741/A	Connection Diagram
Note		11 / 13	All rights reserved. Copyright © 2015 iLOQ Oy http://www.ilooq.com
			

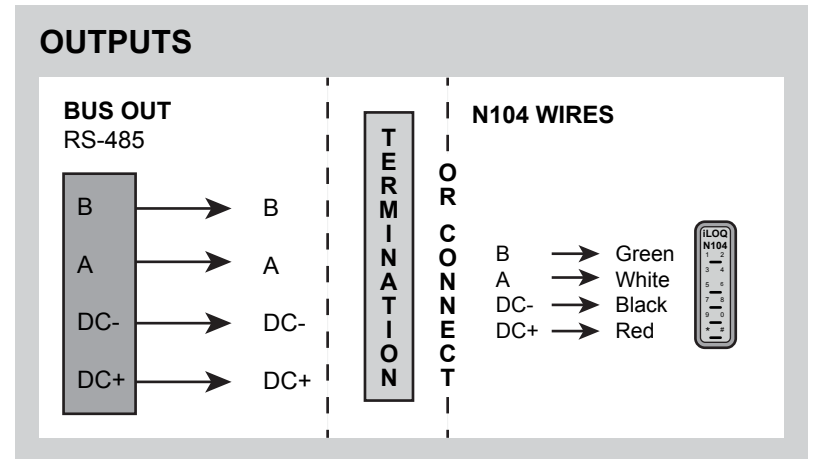
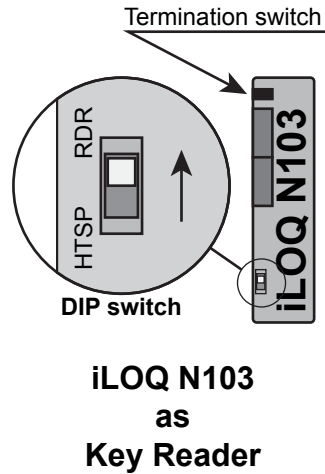
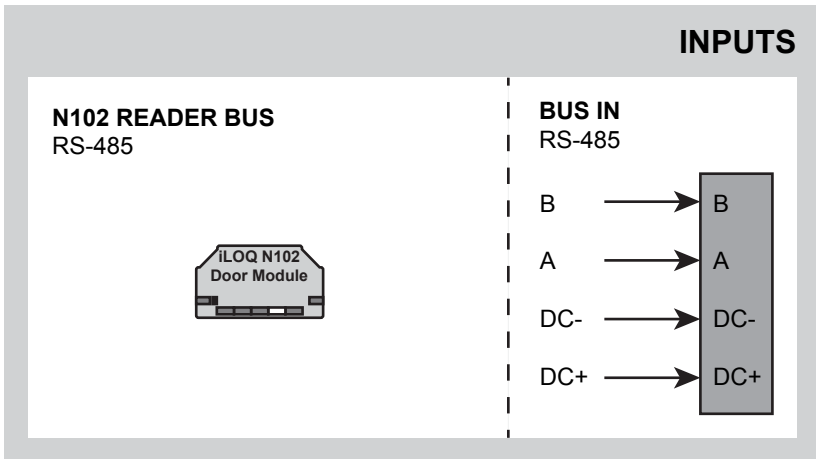
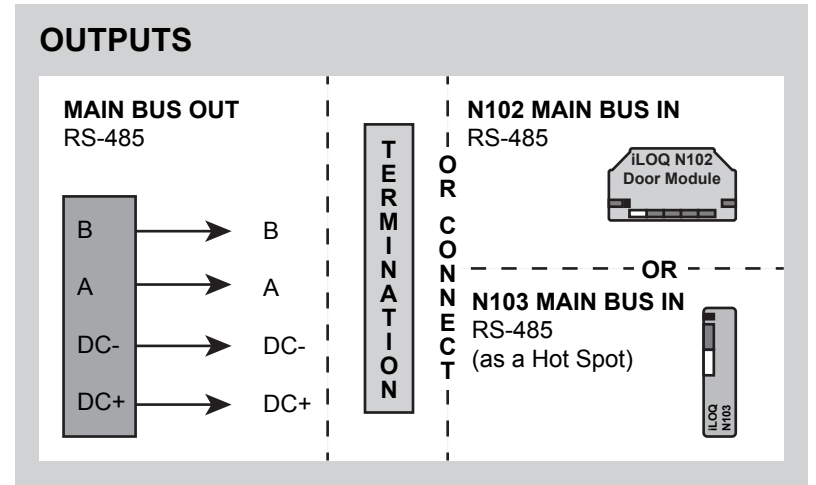
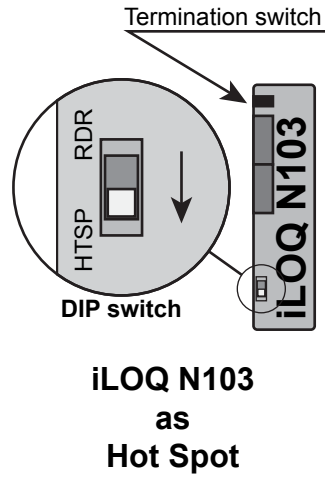
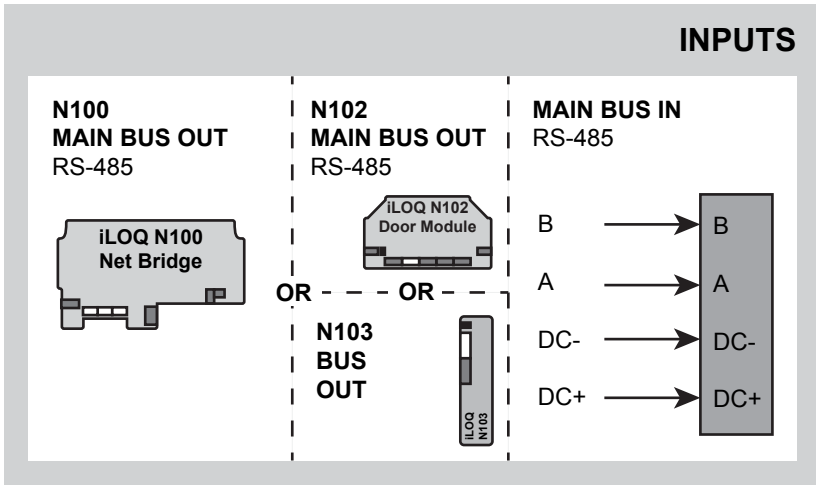

Title			
iLOQ S10 Online N103 Key Reader / Hot Spot			
Author	Date	ID and Rev.	Document type
	15.6.2015	53741/A	Connection Diagram
Note		All rights reserved. Copyright © 2015 iLOQ Oy http://www.ilooq.com	
12 / 13			

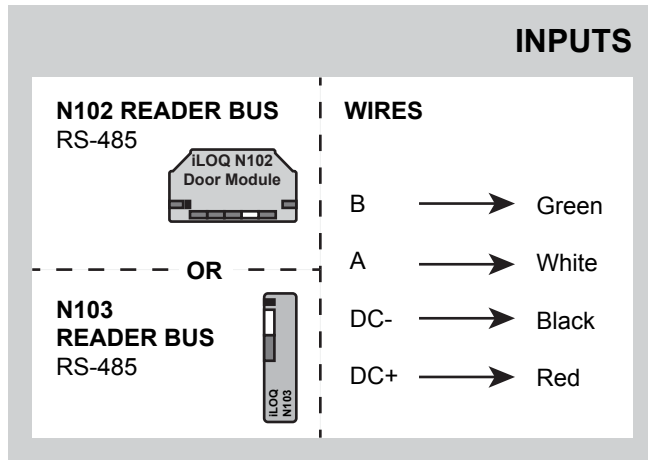

Title			
iLOQ S10 Online N104 RFID Reader			
Author	Date	ID and Rev.	Document type
	15.6.2015	53741/A	Connection Diagram
Note			All rights reserved. Copyright © 2015 iLOQ Oy http://www.ilq.com
13 / 13			
			